

SN-50 Serial Syringe Pump User Manual

Version: 2.6

Sino Medical-Device Technology Co., Ltd.

Statement:

The information contained in this user manual is based upon the experience and knowledge acquired by Sino Medical-Device Technology Co., Ltd. (hereinafter referred to as Sinomdt) before publishing this manual.

Sinomdt firmly believes that the information provided with this manual is correct and reliable, but no guarantee is provided for the content of the manual. This user manual aims at providing guidance on use, operation and maintenance of the syringe pump. Therefore, Sinomdt shall not be responsible for any property loss or physical injury caused by citing the content of this manual for other use.

All copyrights reserved. Duplication and dissemination of the content and information in this manual are prohibited without prior consent from Sinomdt.

The content of the manual is subject to changes due to product upgrade or improvement without further notice.

Please carefully read through this user manual before installing and using the SN-50 series syringe pump.

Contents



1. SAFETY INFORMATION	5
1.1 Indication for User Manual	5
1.2 General Introduction to Safety	5
1.3 Electric/Mechanical Safety	6
1.3.1 Electric Safety.....	6
1.3.2 Operating Safety	7
1.4 Symbols and Labels.....	8
1.4.1 Safety Symbols	8
1.4.2 Transportation Symbols.....	9
1.4.3 Equipment nameplate.....	10
1.4.4 Applicable Standards List.....	12
2. PRODUCT INTRODUCTION.....	12
2.1 Provisions.....	12
2.2 Model Coding.....	13
2.3 Working Principle and application	13
2.3.1 Working Principle	13
2.3.2 Intended use.....	13
2.3.3 Applicable user	13
2.3.4 Intended operator	13
2.3.5 Taboo.....	14
2.4 Technical Characteristics and Parameters	14
2.4.1 Setting range of flow rate	14
2.4.2 Accuracy.....	14
2.4.3 Purge rate.....	14
2.4.4 Display range of volume delivered	14
2.4.5 Setting of delivery limit.....	14
2.4.6 Occlusion detection pressure	15
2.4.7 History Record.....	15
2.4.8 Alarms	15
2.4.9 Power Supply.....	15
2.4.10 Environment	15
2.4.11 Overall Dimensions:.....	16

2.4.12 Net Weight	16
2.4.13 Syringes support.....	16
2.5 Compositions	16
2.5.1 Compositions and Part Introduction of SN-50C6 System	17
2.5.2 Compositions and Part Introduction of SN-50F6 System.....	18
2.5.3 Compositions and Part Introduction of SN-50C6T System.....	19
2.6 How to Use SN Serial Syringe Pump	20
2.6.1 Startup	20
2.6.2 System Self-test for Startup.....	20
2.6.3 Loading Syringe.....	20
2.6.4 Flow Rate Setting.....	21
2.6.5 Delivery Limit Value Setting	21
2.6.6 Occlusion Detection Pressure Setting	22
2.6.7 Syringe Code Selection	22
2.6.8 Fast Feeding.....	23
2.6.9 Delivered Volume Query	23
2.6.10 Alarm Prompt.....	23
2.6.11 Syringe Calibration	26
2.6.12 Body-Weight Mode (SN-50C6T)	27
2.6.13 Standard RS232 Interface	27
2.6.14 Multi-channel Syringe.....	28
2.6.15 Device Fixation.....	28
2.7 Battery charging management.....	30
2.7. 1 Battery	30
2.7.2 Charge.....	31
3. TROUBLESHOOTING	33
4. MAINTENANCE.....	34
5. INFUSION CHARACTERISTICS	35
5.1 Infusion Accuracy of Pump.....	35
5.2 Properties of flow rate accuracy	35
5.3 Occlusion Response Characteristics	37
6. PRODUCT STANDARD CONFIGURATION	38
7. RELATED INFORMATION	39

1. Safety Information

1.1 Indication for User Manual

In this manual, the following information is used for emphasizing the related information or potential risk to patients or equipment.

	Caution: Used for indicating the possible caused damage to the equipment or environment
	Warning: Used for indicating the possible caused injury or death.
Attention: Used for emphasizing the important instructions. These instructions relates to how to use the manual and the product, or providing the additional information like detailed explanations, prompt or reminding.	

1.2 General Introduction to Safety

According to the electric safety classification, this is a Class I, CF type, non-portable equipment with internal power supply. The pump is a splash-proof device at IPX4 class.

Syringe: The users are required to use the syringe meeting national standards with medical admittance license. The default is Shandong Weigao Jierui branded syringe at specification of 10mL, 20mL, 30mL, and 50mL. The user-defined syringe can also be used through “Automatic syringe calibration” function, please see 2.6.11 in the Manual.

The followings are the brief introduction to safety precautions:

- Operators are required never to open the casing of the device.
- Never to cause malfunction or short circuit to the safety parts in the built-in device.
- Even in case of abnormal operation of the device, unauthorized maintenance is prohibited. It is required to immediately contact the qualified and authorized personnel from Sinomdt. The authorized maintenance personnel can ask for the corresponding data from our company including circuit diagram and parts list, etc.
- There are no components required for maintenance inside the device.
- It is required to follow all the warnings and cautions, no matter they are specified or

implied.





- It is required to follow all the instructions on safety label.

1.3 Electric/Mechanical Safety

The maintenance personnel who have passed the training held by Sinomdt are required to open the casing, change battery and mechanical parts. Otherwise, safety problems of the device may be caused.







The followings are the brief instruction to the warning information.





1.3.1 Electric Safety

	Warning: Risk of electric shock: For protecting patients and medical staff, secure grounding for the device and power supply socket is required. Connecting 2-pin plug to the 3-core cable is prohibited.
	Warning: Risk of electric shock: It is prohibited to open the casing of the device during operation or with power connection. The authorized technicians are required to open the casing.
	Caution: Before using, the customers are required to check if there is obvious damage on the device and cables those possibly cause danger to patients or lower performance of the device. It is recommended to make regular check at frequency of once a week or more. In case of obvious damage found, it is recommended to change the damaged parts before using.
	Caution: Regular safety test is required for the device including leakage current test and insulation test. It is recommended to the test it at frequency of once a year or to follow the requirements as per regulation and test specification.
	Caution: Power disconnection is required before starting cleaning. Cleaning methods: clean the device surface with a soft brush or a piece of soft

	cloth; clean the connector or panel edge with a brush or a piece of cloth soaked in neutral cleanser/cold disinfectant or 70% alcohol or isopropyl alcohol. Prevent the cleanser or disinfectant from coming into the device. Pay more attention to the connector and panel edge.
--	---



1.3.2 Operating Safety













	<p>Warning:</p> <p>It is required to operate the device in the specified environment. Otherwise, abnormal operation to the device will be caused.</p> <p>Specified working conditions:</p> <p>Working temperature: +5~+40°C</p> <p>Relative humidity: 20%~80%</p> <p>Atmospheric pressure: 86kPa ~ 106kPa</p> <p>Power: AC 110~230V; (50/60Hz)±1 Hz</p> <p>Max. power: 30VA (SN-50C6), 30VA (SN-50C6T), 40VA (SN-50F6)</p>
	<p>Warning:</p> <p>It is not suitable to be operated in an environment with oxygen gas and containing flammable anesthetic of nitrogen oxide. Otherwise, there is the risk of explosion.</p>
	<p>Warning:</p> <p>Using improper or non-calibrated syringe probably cause inaccurate speed or injection amount.</p>
	<p>Warning:</p> <p>It is required to prevent air from entering human body during using this device.</p>
	<p>Warning:</p> <p>Do not use this device in the situation with high pressure oxygen cabin or MR testing environment</p>
	<p>Caution:</p> <p>Keep the environment clean; avoid vibration; keep it away from corrosive medicines, dust, and environment with high temperature and humidity.</p>

	<p>Caution: Electromagnetic interference: Make sure to keep the operation environment of the device free from strong electromagnetic interference, e.g. the interference caused by telegraphy machine and mobile phone.</p>
	<p>Caution: This device is not suitable for the injection of the following medical solution: --Insulin --Chemotherapy drugs.</p>
	<p>Reminding: When RS232 port not in use should be covered with protective cover.</p>
	<p>Caution: The syringes used must be disposable and have SFDA registration certificate(in China) or CE certificate(in Europe),it's forbidden to re-use them; After use,the disposable syringe should be treated as medical waste by operator.</p>
	<p>Caution: Power line and battery provided by SinoMDT should be used,otherwise the device will not work properly.</p>

1.4 Symbols and Labels





1.4.1 Safety Symbols

	Please read user manual before use
	"On/Off" or power-on
	Functional grounding

	Protective grounding
	High voltage
	Refer to attached documents
	CF type application part
	AC
	Battery level
	Manufacturer
	European authorized representative
	Date of production
	Serial number
	CE certification mark. The digital code of the mark is the code of the certification institution.
	Sinomdt's logo
IPX4	Water-proof level 4,protected against splashed water,stay harmless from splashed water at any angle
	Recycle after sorting

1.4.2 Transportation Symbols

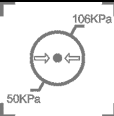
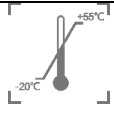
	Fragile: Be careful
---	---------------------

	Keep dry
	Storage humidity: Do not expose the product in the environment at humidity beyond the specified value.
	The air pressure can't be more than 106KPa or less than 50KPa during transportation.
	Temperature: Do not expose the product in the environment at temperature beyond the specified value.
	Direction: with this side up

1.4.3 Equipment nameplate



SINO MEDICAL-DEVICE TECHNOLOGY CO., LTD.
www.sinomdt.com

Product Name : Syringe Pump

Product Model : SN-50C6

Safety Class : Class I  IPX4

Voltage : AC 110V-230V

Power Frequency : 50Hz/60Hz

Rated Power : 30VA











 Sino Medical-Device Technology Co., Ltd.

Add: 6th Floor, Building 15, Majialong Industry Zone,
Nanshan District, Shenzhen, P.R.China

 Shanghai International Holding Corp.GmbH(Europe)
Add: Eiffestrasse 80,20537 Hamburg, Germany

 0123

SINO MDT SINO MEDICAL-DEVICE TECHNOLOGY CO., LTD.
www.sinomdt.com

Product Name : Syringe Pump Voltage : AC 110V-230V
 Product Model : SN-50C6T Power Frequency : 50Hz/60Hz
 Safety Class : Class I  IPX4 Rated Power : 30VA







 **Sino Medical-Device Technology Co., Ltd.**
 Add : 6th Floor, Building 15, Majialong Industry Zone,
 Nanshan District, Shenzhen, P.R.China

 **Shanghai International Holding Corp.GmbH(Europe)**
 Add : Eiffestrasse 80,20537 Hamburg, Germany

 **0123**





SINO MDT SINO MEDICAL-DEVICE TECHNOLOGY CO., LTD.
www.sinomdt.com

Product Name : Syringe Pump Voltage : AC 110V-230V
 Product Model : SN-50F6 Power Frequency : 50Hz/60Hz
 Safety Class : Class I  IPX4 Rated Power : 40VA







 **Sino Medical-Device Technology Co., Ltd.**
 Add : 6th Floor, Building 15, Majialong Industry Zone,
 Nanshan District, Shenzhen, P.R.China

 **Shanghai International Holding Corp.GmbH(Europe)**
 Add : Eiffestrasse 80,20537 Hamburg, Germany

 **0123**

1.4.4 Applicable Standards List

Harmonized Standard	Description
ISO 14971:2007	Medical devices - Application of risk management to medical devices
EN 980:2008	Graphical symbols for use in the labelling of medical devices
EN 1041:2008	Information supplied by the manufacturer with medical devices
EN 60601-1:1995+A1+A2	Medical electrical equipment - General requirements for safety
EN 60601-1-2:2007	Medical electrical equipment - General requirements for safety - Collateral standard: Electromagnetic compatibility; Requirements and tests
EN 60601-1-4: 1996	Medical electrical equipment - Part 1-4: General requirements for safety - Collateral standard: Programmable electrical medical systems
EN 60601-2-24:1998	Medical electrical equipment - Part 2-24: Particular requirements for the safety of infusion pumps and controllers

2. Product Introduction

2.1 Provisions

SN-50 serial syringe pumps are the volumetric injection pumps with multi-channel and multi-speed control. The product features high precision of timing, stable flow rate and less quantity of liquid required. The products are particularly suitable for emergent delivering the key medicines like sodium nitroprusside, dopamine, isopropyl alcohol and anti-bacteria medicines. SN-50 serial syringe pumps use 10mL, 20mL, 30mL or 50mL disposal sterile syringes (hereinafter collectively referred to as syringe) calibrated by the device. In case of clamping the syringe on to the device, the device will automatically identify the specification of the syringe clamped. In addition, the device is equipped with multi alarming functions for achieving a safe and reliable injection. The products are for control on delivery volume and flow rate during clinical solution injection (medicine liquid,

nutrition liquid and blood) into the body of patients.

2.2 Model Coding

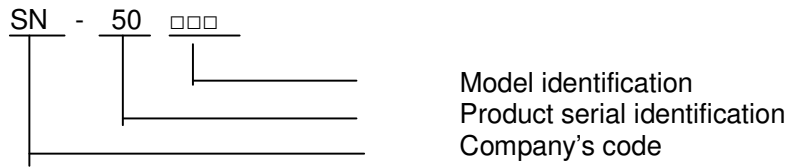

The serial products include the following models:

SN—50C6

SN—50F6

SN—50C6T

2.3 Working Principle and application

2.3.1 Working Principle

This is a volumetric pump different from the constant pressure pump (e.g. peristaltic pump). The output of solution within a certain period will not be affected by the resistance in the infusion channel. When the pressure reaches a certain value, the occlusion alarming system equipped on the pump will give sound, light alarm and stop running, meaning that the actual output volume complies with the preset output volume. The device is equipped with a micro-feeding system. In virtue of the circuit, this system can obtain a larger speed adjustment range. Once any of the four kinds of syringe with specification of 10mL, 20mL, 30mL or 50mL is installed on to the device, the identification system will automatically adjust ready the proper flow rate up limit. At this time, as long as to set ready the desired injection speed and press the startup key, the device will start operation.

2.3.2 Intended use

The syringe pumps are used for injecting drugs into human body with accurate volume, stable and flow rate, long time and constant injection.

2.3.3 Applicable user

Used for drug injection for adult, paediatric and neonate for infusion therapy.

2.3.4 Intended operator

The doctor, nurse or well trained and qualified professional medical care personnel in the

hospital.

2.3.5 Taboo

Taboo drugs: Insulin is not suitable for syringe pump.

2.4 Technical Characteristics and Parameters

2.4.1 Setting range of flow rate

50mL syringe: 0.1~1500mL/h; 0.1mL/h per step when rate is under 1000mL/h, and 1mL/h per step since 1000mL/h

30mL syringe: 0.1~900.0mL/h; 0.1mL/h step

20mL syringe: 0.1~600.0mL/h; 0.1mL/h step

10mL syringe: 0.1~400.0mL/h; 0.1mL/h step

Measurement unit of calibrating measurement equipment: ml/h

2.4.2 Accuracy

Accuracy of flow rate: within $\pm 2\%$ (the accuracy of syringe should be within $\pm 1\%$.)

Mechanical accuracy: within $\pm 1\%$

2.4.3 Purge rate

50mL syringe: 1500mL/h;

30mL syringe: 900.0mL/h;

20mL syringe: 600.0mL/h;

10mL syringe: 400.0mL/h

2.4.4 Display range of volume delivered

0.1~9999mL,

For 0.1~999.9mL, the display resolution is 0.1mL; and for those over 1000mL, it is 1mL.

2.4.5 Setting of delivery limit

0.1mL~9999mL,

0.1mL step when value is under 1000mL; and for those over 1000mL, it is 1mL step.

2.4.6 Occlusion detection pressure

High (H): 800mmHg±200mmHg (106.7kPa±26.7kPa)

Center (C): 500mmHg±100mmHg (66.7kPa±13.3kPa)

Low (L): 300mmHg±100mmHg (40.7kPa±13.3kPa)

2.4.7 History Record

These serial products can maximally store 1000 pieces of history records. The record includes the following information:

flow rate, alarm data, total volume delivered, pipeline occlusion pressure, delivery limit and syringe specification.

2.4.8 Alarms

For a safe and reliable infusion, these serial products are equipped with the following alarm functions:

'Occlusion', 'Nearly empty', 'Finish', 'Syringe dislocated', 'Plunger/Clutch disengaged', 'Battery low', 'Battery exhausted', 'Power cable disconnected', 'Flow rate over limit', 'Volume over limit', 'System error', 'Non-operation time over', please refer to 2.5.9 for further details.

2.4.9 Power Supply

Power Voltage: AC.110V~230V

Power frequency: (50/60) Hz±1Hz

Battery voltage: Rated DC.12V

Battery capacity: A fully charged battery can support a channel working at the speed of 5mL/h for more than 6 hours.

Maximum power: 30VA (SN-50C6), 30VA (SN-50C6), 40VA (SN-50F6)

Operating method: intermittent load continuous operation

Note: Before the first time of use, the battery must be charged for minimum 12 hours.

2.4.10 Environment

Working conditions:

Temperature: +5~+40°C

Humidity: 20%~80%

Conditions for transportation and storage:

Temperature; -20~+55℃

Humidity: ≤95%

2.4.11 Overall Dimensions:

Syringe pump	SN-50F6	354mm (W) × 190mm (H) × 128mm (D)	Dual channel
Syringe pump	SN-50C6	306mm (W) × 135mm (H) × 127mm (D)	Single channel
Syringe pump	SN-50C6T	306mm (W) × 135mm (H) × 127mm (D)	Single channel with body-weight mode

2.4.12 Net Weight

SN-50F6: 3.5kg (including clamp);

SN-50C6: 2.3kg (including clamp);

SN-50C6T: 2.3kg (including clamp);

2.4.13 Syringes support

Syringes including models of 10ml、20ml、30ml、50ml from up to 12 different manufacturers can be stored in this device. Each trademark of manufacturer is distinguished by numbers of 01, 02,, 11, 12, in which “01” represents the syringe with the trademark of “WEGO” what is recommended and set with “01”as default. Syringes of the other numbers “XX” can be used by the only way of recording parameters of 10ml、20ml、30ml and 50ml model from user choose after “XX” through calibrating function.

	<p>Warning: If the user-defined syringe is not calibrated, it may cause inaccurate injection. The syringe used must be CE certified or has local market entry permit.</p>
---	--

2.5 Compositions

SN-50 serial syringe pump is composed of the casing, syringe clamp, control plate, and pusher. Refer to the table for the model and dimensions; refer to the figure for product structure.

2.5.1 Compositions and Part Introduction of SN-50C6 System

Figure 2.5.1: sn-50c6 syringe pump

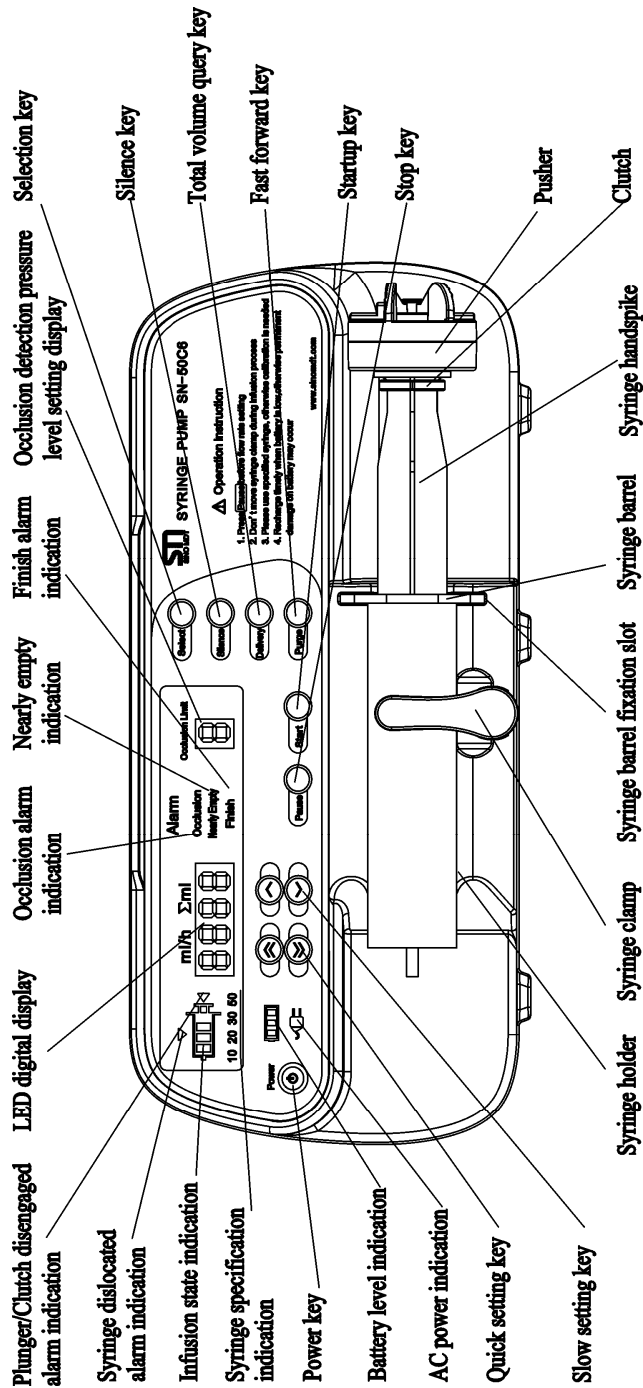

2.5.2 Compositions and Part Introduction of SN-50F6 System

Figure 2.5.2: sn-50F6 syringe pump

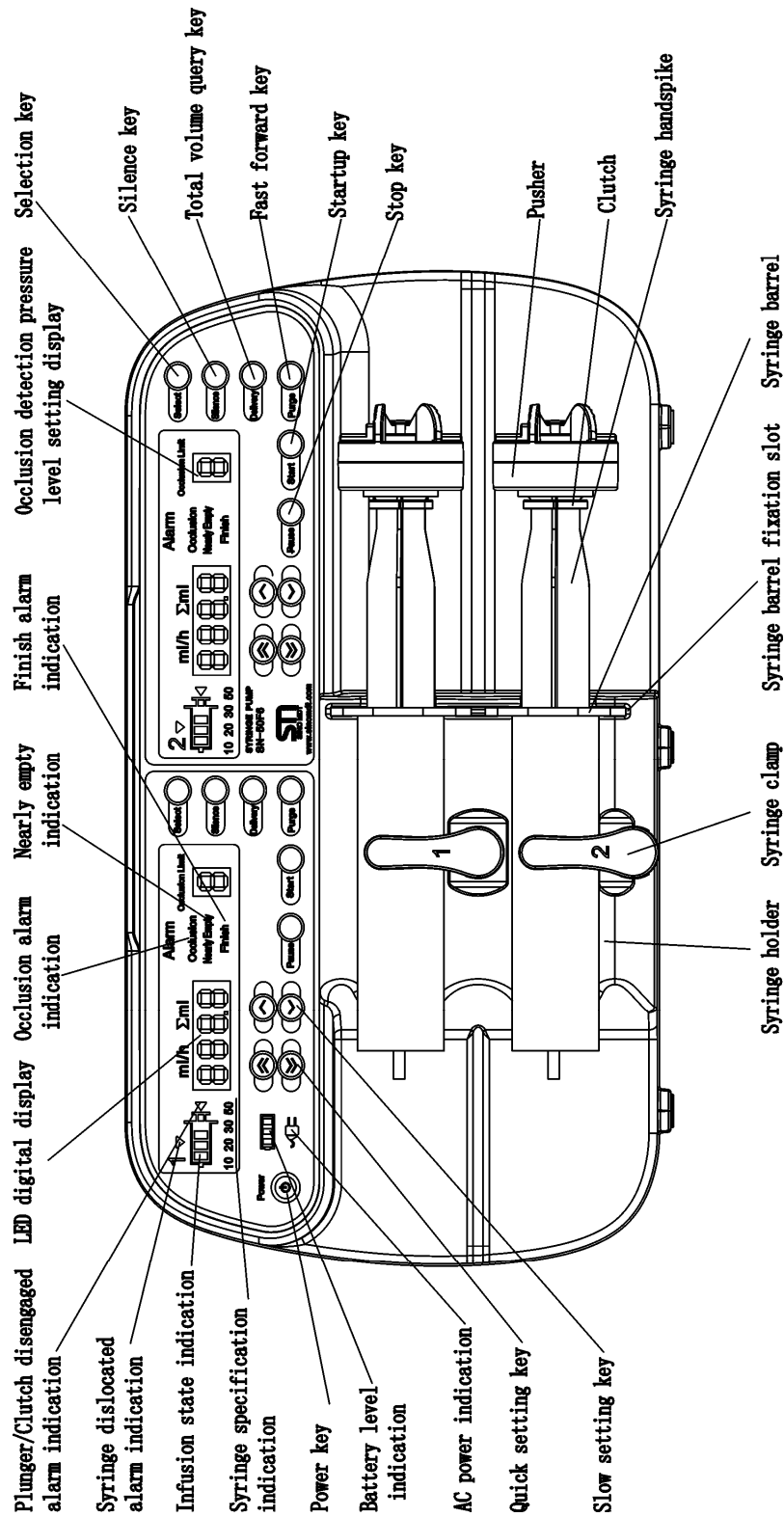

2.5.3 Compositions and Part Introduction of SN-50C6T System

Figure 2.5.3: sn-50C6T syringe pump

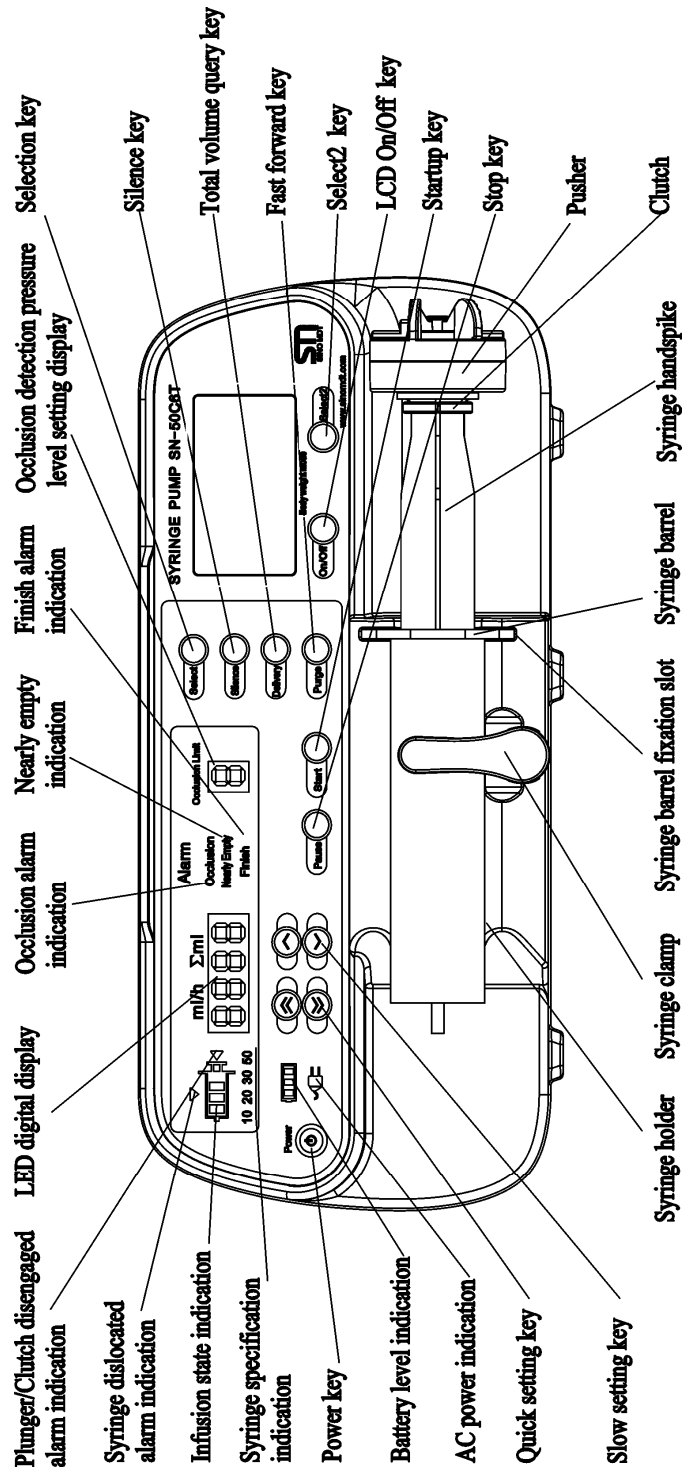



2.6 How to Use SN Serial Syringe Pump

2.6.1 Startup

After connecting utility power (AC) through, AC power indicator lights, and then the pump is in power-on state.

2.6.2 System Self-test for Startup

After pressing power key  for 1.2 seconds, the system starts self-test. In case of no ERR displayed on the LED digital display, it means a normal pump. At this time, the

device is in a standby state. At this time, if to press and hold  key, the device enters a hibernation and power saving state. At this time, the four-bit LED digital

display shows the sign of “-” in turn. Press any key of this channel except  key to

enable this channel. And, if press the power key  for 1.2 seconds, the device will

power-off. In injection status, first need to press  key to stop injection,

then press key  to power off.

The data saved in the storage chip will not get lost after power off.

2.6.3 Loading Syringe

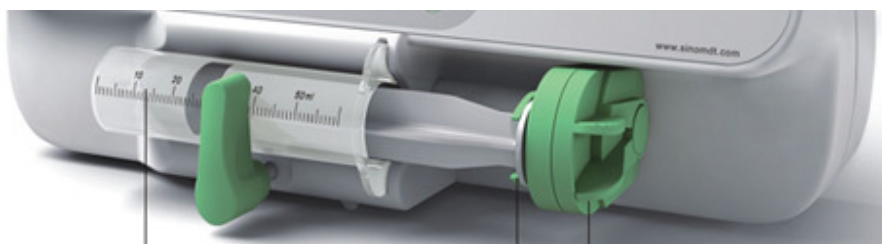



- After filling up the syringe with solution and expelling air out, then put the syringe into the syringe holder.



Warning:

Before installing the syringe, it is required to expel air out of the syringe to avoid air embolism.





	<p>Caution:</p> <p>The barrel of the syringe is required to be inserted into the injection pump barrel fixation slot.</p>
---	--

- Fix the syringe barrel securely with the syringe clamp; hold tightly the pusher to make the clutch open; move the pusher to the end of the syringe handspike; loosen the pusher to release the Clutch and to lock the syringe push plate between the pusher and the Clutch.
- Press and hold the Fast Forward key and do not release it until solution coming out from the needle tip.
- After setting all the parameters ready, introduce the needle into vein (artery) of the patients, and then press  key. Thus, the pump starts infusion.

	<p>Warning:</p> <p>Before infusion, it is required to expel air thoroughly out from the injection connecting pipe to avoid harm against the patient caused by air embolism.</p>
---	--





2.6.4 Flow Rate Setting

- After power on, the pump use the last set flow rate as the default flow rate, and the user can use the four setting keys to set infusion flow rate, and the corresponding values will be shown on the LED display.





-  are the quick setting keys;  are the slow setting keys; in pause state, press and hold  to quickly adjust the flow rate faster. Press and hold  to adjust the flow rate slower.
- Setting can be performed only in standby or pause state. After startup, all the flow rate adjustment keys are locked.

2.6.5 Delivery Limit Value Setting







- Delivery limit value setting is for setting the limit value of total infusion volume.

- In standby or pause state, use  key to enter delivery limit value setting state. At this time,  indicator lights, and LED displays the current limit value. At this time, the four setting keys can be used for adjusting the limit value for total infusion volume and the corresponding values are shown on the LED display. In startup state, the datum is locked. At this time, after pressing  key, only the set limit value can be viewed.
- In standby or pause state, simultaneously press  key and  key, the set limit values will be reset.

2.6.6 Occlusion Detection Pressure Setting

- There are three levels of occlusion detection pressure: High (H), Center (C), and Low (L). The pump use the last set pressure level as the default after power on.
- In standby or pause state, use  key to enter occlusion detection pressure setting state. At this time, LED will display OCCL. Press   or   to switch among (H), (C) and (L).

2.6.7 Syringe Code Selection



- If the syringe is not installed, pressing  key will cause 'Syringe dislocated' alarm; if the syringe code is not set, after pressing  key, the device will automatically set to the code of same syringe specification as the previous time and start infusion.
- In standby or pause state, use  key to enter syringe code setting. At this time, '—XX—' will be shown on the LED display. 'XX' indicates the syringe code. Press   or   to select the desired syringe code in the syringe

code list.

2.6.8 Fast Feeding

There are two kinds of fast feeding:

- The volume of fast feeding is NOT added up to the total volume.

In standby or pause state, after pressing and holding  key, the device will perform infusion at the preset purge rate. At this time, the fast feeding solution volume is not added up to the total infusion volume. LED display shows the fast feeding infusion flow rate of the current syringe specification; after releasing  key, the LED display will be back to display the originally set flow rate.

- Fast feeding volume is added up the total volume.

When the device performs infusion at a certain and normal speed, after pressing and holding  key, the fast feeding solution volume is added up to the total infusion volume. At this time, the device dynamically adds up the output of the pump: in case of total volume measurement is below 1000mL, it is to increase by unit of 0.1mL; after the total accumulated volume reaches 1000mL, it is increase by unit of 1mL.

2.6.9 Delivered Volume Query

- In any state, it is able to check the total infusion volume of solution into the patients'

body by pressing  key.

- In any state, it is able to press  key and  key to reset the total infusion volume.

2.6.10 Alarm Prompt

- **Nearly Empty:**

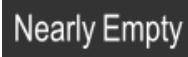
When the residual amount of solution reaches to $1.5\text{mm}\pm 0.8\text{mm}$, the  indicator on the panel flashes and gives voice alarm with interval at the same time.

- **Finish:**

When the solution in the syringe is almost finished,  indicator flashes with voice alarm at interval, and the LED digital display shows KVO flow rate of 0.5mL/h. At this time, the pump enters KVO infusion mode.

- **Occlusion:**

In case of unsmooth infusion caused by occlusion needle or bended pipeline, when the liquid pipeline system reaches to the set threshold value, the  indicator on the panel flashes with voice alarm at interval. At this time, pressing

 key the alarm will be mute.

Note: There is a course from being entirely occlusion to alarm given for the occlusion alarm of the syringe by most of manufactures. Along with the rise of pump output, the system pressure increases. When the system pressure reaches to the set pressure value, occlusion alarm starts up.

- **Syringe Dislocated:**

During normal infusion, if the syringe clamp is not pressed on the syringe properly, the pump will give voice alarm at interval with flashing  indicator and stop working.

- **Plunger/Clutch Disengaged:**

If the push plate of the syringe is not locked between the push head and clutch, or the clutch is not closed, the pump will give voice alarm at interval with flashing  indicator after starting up the infusion. The device can not enter infusion state.

During normal infusion, if to press down the push head, the clutch will open. Then, the pump will give voice alarm at interval with flashing  indicator and stop working.

- **Flow Rate Over Limit:**

If the set speed is over the range of flow rate of 10mL, 20mL, and 30mL, pressing  key can not start up the pump. The LED display will show the flow rate setting value of 10CC, 20CC, and 30CC respectively in turn and it gives voice alarm at interval.

- **Volume Over Limit:**

When the solution amount of the pump reaches to the set limit value, the pump will give voice alarm at interval. At this time, the pump stops working, the speed value and limit value will be shown on the LED display alternately. The limit value is displayed with voice alarm.

- **Power Cable Disconnected:**

After switching power on, if AC power supply is not connected through or poor contact of power cord occurs during using,  indicator flashes (All the three block flash.), the pump will give voice alarm at interval.

- **Battery Low:**

In case of low battery,  indicator flashes (One block flashes.) the pump will give voice alarm at interval. At this time, the pump is still able to work for about 30 minutes at the flow rate of 5mL/h.



- **Battery Exhausted:**

When the battery electricity is totally exhausted, the pump will stop working.  indicator flashes (All the three block flash.) the pump will give voice alarm at interval.

- **System Error:**

Mis-operation may cause program error. At this time, “ERR” will be shown on the LED digital display with voice, light alarm at interval. After pressing  key to power off the device for restart, if it is still with system error alarm, please contact the authorized service provider in your region or Sinomdt company.

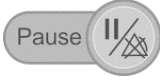
- **Non-operation Time Over:**

In status of power on, in case of no any operation for more than 2 minutes, the pump will give interval voice alarm and show “NOOP” at LED, then press  key to enter sleeping mode, or press  key to remove this alarm. If continually occur this alarm, after the second time press  key, the pump will show “NOOP” but without voice.

- **Silence:**

Except the Battery Exhausted alarm and System Error alarm, all the other alarms can be mute by pressing  key. In case of no operation for longer than 2



minutes after mute, the voice alarm will be given again. Except Battery Low alarm and



Battery Exhausted alarm and System Error, it is to press  key to remove alarm and enter pause state.



The alarms happened in injection process, such as Finish, Occlusion, Syringe Dislocated, Plunger/Clutch Disengaged, Flow Rate Over Limit, Volume Over Limit, Battery Low, Battery Exhausted, System Error, are the high level alarms; The liquid is going to be finished (nearly empty) is middle level alarm; Other alarms are low level alarms, such as Non-operation Time Over.



2.6.11 Syringe Calibration

- The unit of syringe calibration: mL/h, mmHg or kPa
- In standby or pause state, pull the syringe plunger to be calibrated to the position of roughly 5mm over the rated scale line (Fully filling up with water is required. It is also required to be connected securely with extension tube and scalp needle for ensuring the accuracy of the calibration.) and are to be properly clamped on the device.

- Press and hold  key to push the plunger to the rated capacity scale line (10mL, 20mL, 30mL or 50mL) of the syringe. Release  key.

- Press and hold  key to enter calibration state of the syringe. At this time, the infusion state indicator of  flashes at the same time; release





 key. At this time, the LED display shows the code of the current calibrated syringe on this channel on this device, the user also can press  

or   to set the desired code for the calibrated syringe.

- After pressing  key, the syringe starts automatic calibration. During the automatic calibration process, to avoid calibration fail, please do not operate the device.

- When the plunger is pushed to the end, the device beeps at interval and automatically comes to pause state. Then calibration is completed.

2.6.12 Body-Weight Mode (SN-50C6T)

- Press power switch button on, then press Body-weight Mode button to enable body-weight mode, and the body-weight mode screen lights on.
- Use 'Select 2' button, quick setting keys  , and slow setting keys   to enter dose, patient body weight, drug volume and solution volume, the left LED screen will display final infusion rate automatically.
- The default dose unit is µg/kg/min, press 'Select 2' button for 2 seconds, the unit will turn to mg/kg/h.
- Press 'Start' to run infusion program, the back light of body-weight mode screen will automatically turn off after 2 minutes, when needed, press 'Body-weight on/off' button to turn on the back light of body-weight mode screen again.
- In body-weight mode, any modification of flow rate has to through dose, body weight, drug volume and solution volume to calculate automatically.
- All setting keys are locked and can not be tuned when the infusion program is starting.

Note:

Calculation Formula of flow rate

When the unit of dose is µg/kg/min

$$\text{Flow rate (mL/h)} = \frac{\text{Dose volume}(\mu\text{g/kg/min}) \times \text{Body weight}(\text{kg}) \times \text{Solution volume}(\text{mL}) \times 60}{\text{Drug volume (mg)} \times 1000}$$

When the unit of dose is mg/kg/h

$$\text{Flow rate (mL/h)} = \frac{\text{Dose volume}(\text{mg/kg/h}) \times \text{Body weight}(\text{kg}) \times \text{Solution volume}(\text{mL})}{\text{Drug volume (mg)}}$$

2.6.13 Standard RS232 Interface

- Standard RS232 interface is equipped on the pump for bi-direction communication. Shield cable is required for RS232 communication. The device connected to the RS232 interface is required in compliance with the requirements as per the standard

of IEC60950-1:2005. If needed, please ask for RS232 interface protocol from Sinomdt company for further details. The device connected to this device must be the designated device by Sinomdt company.

2.6.14 Multi-channel Syringe

In case of multi-channel syringe needed, it is recommended to use infusion device with check valve. In case of no check valve in the infusion pipeline, occlusion can not be detected at the patient and medicines will be accumulated. After occlusion solved, the accumulated medicine will be injected into the body of patient at an unknown speed. That causes danger to the patient.

2.6.15 Device Fixation

- By turning the fastener on back of the device, it is to fix the device vertically or horizontally on the supporting pole or bed frame.
- Refer to the following figures for the method to fix it on the vertical supporting pole. Press the cover at rotor shaft to open the fastener at an angle of 90°; turn the handspike to clamp tightly the supporting pole.

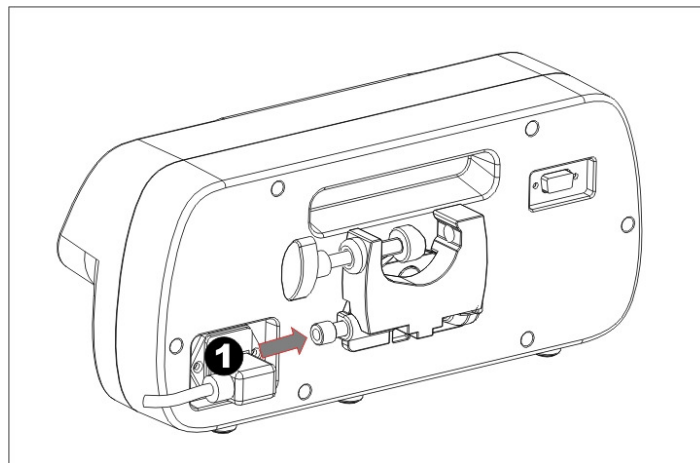

Figure 2.6.15.1: Open the fastener

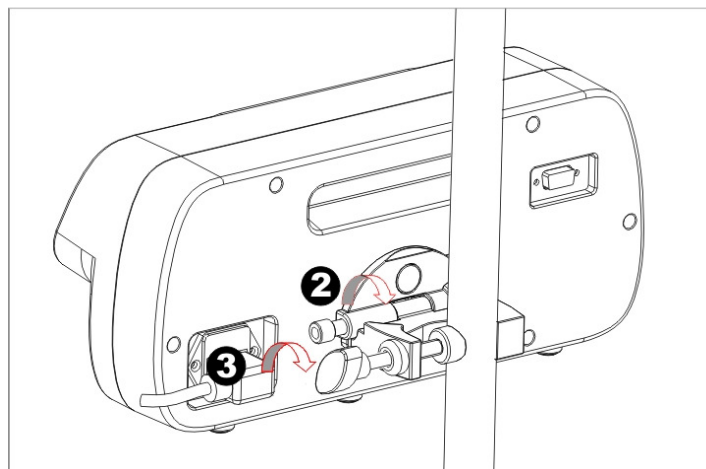

Figure 2.6.15.2: Clamp tightly the supporting pole

- Refer to the following figures for the method to fix it on the horizontal supporting pole. Turn the whole fastener counterclockwise at an angle of 90°; press the rotor shaft cover to open the fastener for 90°; turn the handspike to clamp tightly the supporting pole.

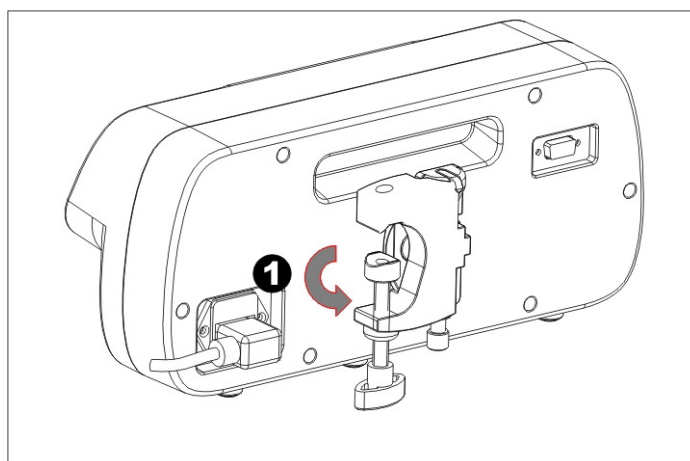

Figure 2.6.15.3: Turn for 90°counterclockwise

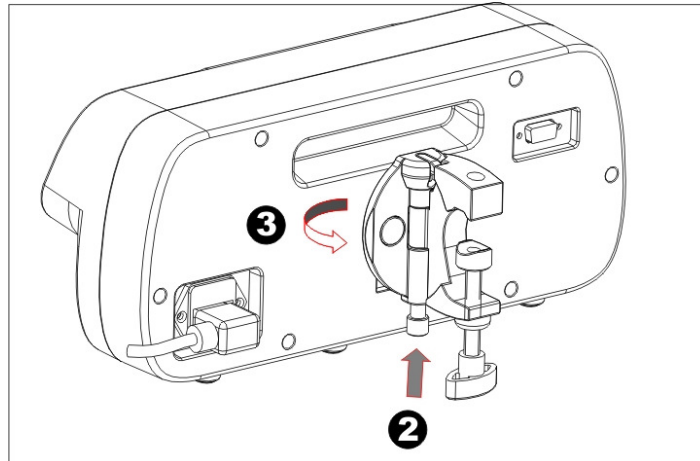

Figure 2.6.15.4: Open the fastener

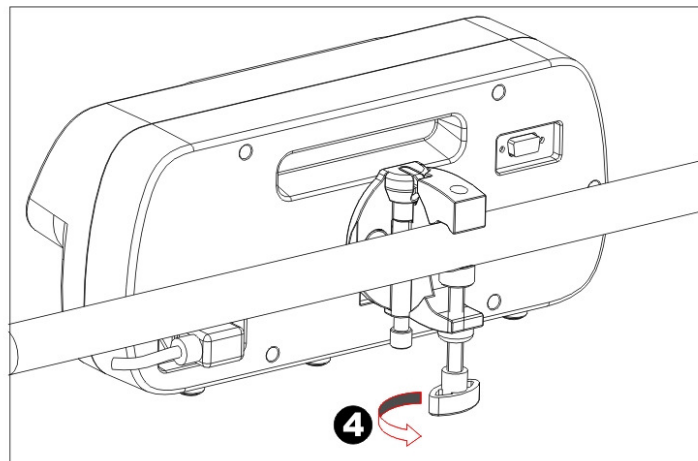

Figure 2.6.15.5: Clamp tightly the supporting pole

2.7 Battery charging management

2.7.1 Battery

1、SN-50F6:

Battery models: 12v 2300mAh 72*51*29mm

2、SN-50C6/SN-50C6T:

Battery models: 12v 2000mAh 72*51*29mm

Out-looking of NI-MH battery: no distortion, leakage of liquid, etc.

Discharge cut-off voltage is 10V.



Working voltage is above 12V.









charge and discharge time check for the chargeable battery in the pump is required at frequency of once every three months to avoid abnormal operation during use caused by battery end-of-life. The rated discharge time of the battery is three hours. Yet, in case of damaged battery or fail of full charge, the powering time by the battery is not guaranteed. before the first time of use, the battery should be continuously charged for 12 hours in power-off state. In case of long term idle, the pump should be charged once every three months to avoid condemnation caused by automatic discharge. In case of battery low, timely charge or power-off is required. Otherwise, exhaustion may cause damage to the battery. the useless battery should be sent the appointed place by the environment protection department, or mailed to Sinomdt company for disposal to avoid environment pollution.



2.7.2 Charge

This device needs to be charged in power-off status, the charging needs at least 12 hours, which will stop automatically when the battery is full. When charging, first it's constant current, when the battery is going to be full, change to trickle charge, when it's full, stop charging.

Attention:

	Warning: after long term of use, in case of the recess of the membrane, please notify the manufacturer to change. Otherwise, mis-triggering may be caused.
	Warning: because the recessed plastic lamination of keys after long term of use will possibly cause mis-triggering, after completing pressing the fast forward key, it is recommended to carefully check if the speed goes back to the originally set value. If it is the same as the fast forward speed, it is required to power off. Otherwise, the pump will keep an infusion at purge rate. That causes danger to patients. At this time, please notify the authorized maintenance personnel for change the key lamination.
	Warning: in case a broken clutch on the push head, please change it timely. Otherwise, siphon will be caused making the residual solution automatically flow into the body of the patients. Excessive medicine infusion will cause harm to the patients.

	<p>Warning: the syringe barrel must be placed into the fixation slot. Otherwise, infusion without medicine or large amount medicine infusion by siphon will cause harm to the patients.</p>
	<p>Warning: it is a must to use the syringes with the specification and model accurately calibrated by the device. Otherwise, unreliable infusion speed and incomplete infusion may occur. For the designated syringes, we recognize only their overall dimensions and structure. Their biochemical, physical and measuring indexes must be tested and approved by the related supervision authorities.</p>
	<p>Warning: while moving the syringe pump, it is required to pay attention to the connection of syringe, extension tube and needle to avoid harm against the patients caused by poor contact of the connectors.</p>
	<p>Warning: clamping installation following the requirements as shown in the figure or automatic sure fixation is required for the pump. It is prohibited to place it on a flat board without railing by bed. This is to prevent the pump from falling by pulling the pipeline and causing danger to the patients.</p>
	<p>Warning: operation of the pump by unauthorized personnel is prohibited to avoid danger caused to the patients.</p>
	<p>Attention: for testing the speed of the pump, it is required to use the selected syringe.</p>
	<p>Attention: accuracy tolerance of the syringe may decrease the precision of pump output. For testing pump precision, it is required to choose the high accuracy syringe.</p>
	<p>Attention: charge and discharge time check for the chargeable battery in the pump is required at frequency of once every three months to avoid abnormal operation during use caused by battery end-of-life. The rated discharge time of the battery is three hours. Yet, in case of damaged battery or fail of full charge, the powering time by the battery is not guaranteed.</p>

	<p>Attention: before the first time of use, the battery should be continuously charged for 12 hours in power-off state. In case of long term idle, the pump should be charged once every three months to avoid condemnation caused by automatic discharge. In case of battery low, timely charge or power-off is required. Otherwise, exhaustion may cause damage to the battery.</p>
	<p>Attention: the useless battery should be sent the appointed place by the environment protection department, or mailed to Sinomdt company for disposal to avoid environment pollution.</p> <p>Please properly dispose the device at expiration of product life and the scrapped parts during maintenance to avoid environment pollution.</p>
	<p>Attention:</p> <p>The injection process should be monitored by medical professionals regularly</p>

3. Troubleshooting

Symptom	Cause	Corrective actions
Unreliable flow rate	Fail in placing the syringe barrel into the slot in the syringe holder	Correctly re-installed
	Unmatched syringe	Select the calibrated syringe
Battery Low alarm given soon after startup	Fail in charging the battery after the previous use or extremely long time idle after charge.	Power it off for charge
	Improper use of the internal battery, damaged battery	Change the battery

Back-streaming of blood at beginning of infusion	Fail in removing mechanical gap by pressing the fast forward key before introducing the needle into vein	Make sure that there is no air in the infusion pipe; then push the blood back to the vein by pressing the fast forward key
	Fail in placing the syringe barrel into the fixation slot of the syringe	Correctly install the syringe again
Unsmooth moving of the push head	Stuck handspike of the pump by solution	Remove the solution with alcohol

Generally, the product redoubled with failure within the warranty period should be sent to the authorized service provider for maintenance. In case of serious damage caused by misuse, the maintenance will be charged at the reasonable cost. Battery is beyond the scope of warranty.

4. Maintenance

- If replacement of fuse needed, it is to open the fuse holder at back of the pump, remove the fuse cover and place the new fuse on. The fuse required is the quick miniature fuse-links at specification of 2A/250V (Φ5×20).
- The pump is required to make regular cleaning. Use a piece of clean cloth soaked with proper amount cleanser to clean its surface, and then use a piece of clean wet cloth to wipe its surface. Finally, dry it with a piece of dry cloth and place it on a clean rack.
- In case of voice and light alarm given at interval for low battery, timely charge or AC power connection to the pump is required; in case of continuous voice and light alarm for battery exhausted, the pump will come to an end of work. Please power it off immediately. It can not be used until AC power is reconnected. Charge method: In power-off state, it is to connect AC power through to the syringe pump. The AC power indicator lights. Then, the pump is being charge. Note: Continuous charge for 12 hours is required in power-off state.
- In case of long term idle, the pump should be charged once every three months to avoid

condemnation caused by automatic discharge.

- After long term idle, charge and discharge check for the battery is required before reuse to avoid fail of work with internal battery in case of power fail. If abnormal charge and discharge of the battery found, please contact the authorized service provider for changing to the new chargeable battery assembly. Authorized personnel are required for changing the battery. Battery change method: Remove the screw of the back cover; open the back cover to take down the terminal pin; then, screw off the screws of the battery pack to take the old battery out; after placing the new battery in, insert the battery terminal pin into the holder; finally, replace the screws and screw them down.

5. Infusion Characteristics

5.1 Infusion Accuracy of Pump

- The $\pm 2\%$ accuracy of flow rate includes $\pm 1\%$ mechanical accuracy of the pump, and $\pm 1\%$ manufacturing accuracy of the syringe. During supervision and test following the requirement by users or supervision organization, the requirements for syringe accuracy are: the size error of all the sections of the syringe used is below $\pm 1\%$; under the system pressure of positive and negative 13.33kPa, minor leakage from any connecting parts (including the position between rubber plug and syringe wall) is prohibited (Liquid leakage occurs under positive pressure; air enters the infusion system under negative pressure.) The syringe used in accuracy test is WEGO 50ml syringe.

5.2 Properties of flow rate accuracy

Testing syringe: 50 ml Weigao JR-brand Disposable syringe

Testing methods: methods specified by GB9706.27—2005

Testing result is shown as below:

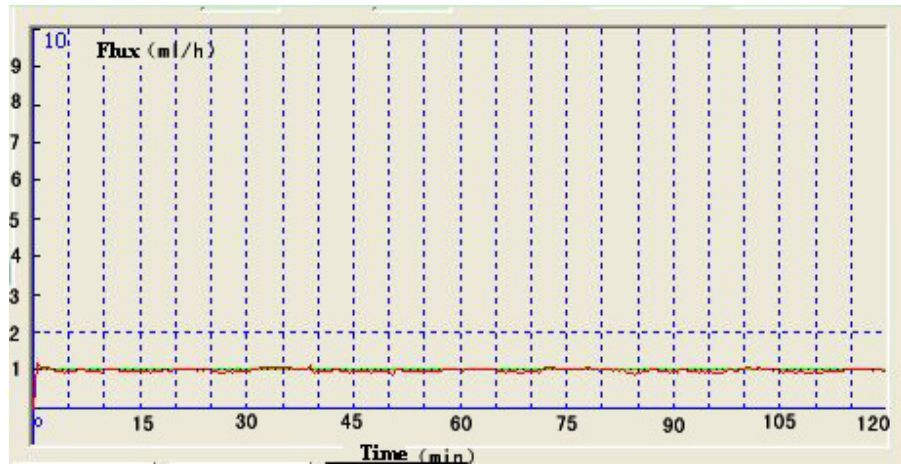

Fig. 5.2.1 The Upcurve when the rate is 5ml/h



Fig. 5.2.2 Horn-shape curves when the rate is 1ml/h

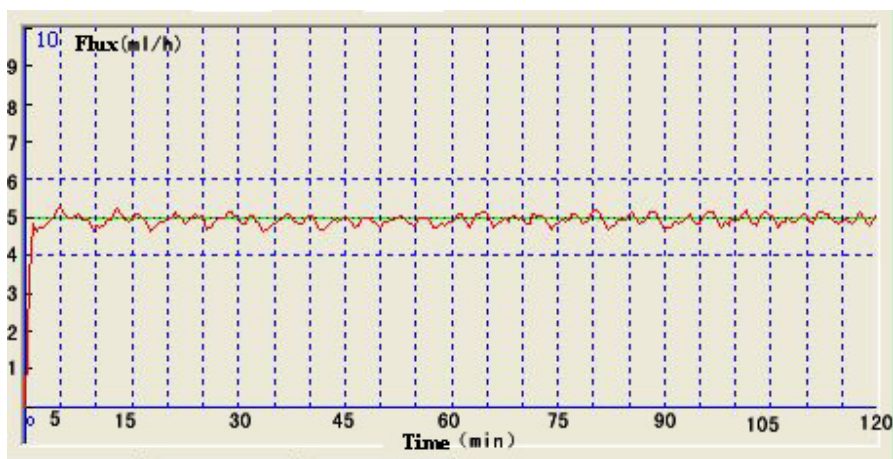

Fig. 5.2.3 The Upcurve when the rate is 5ml/h

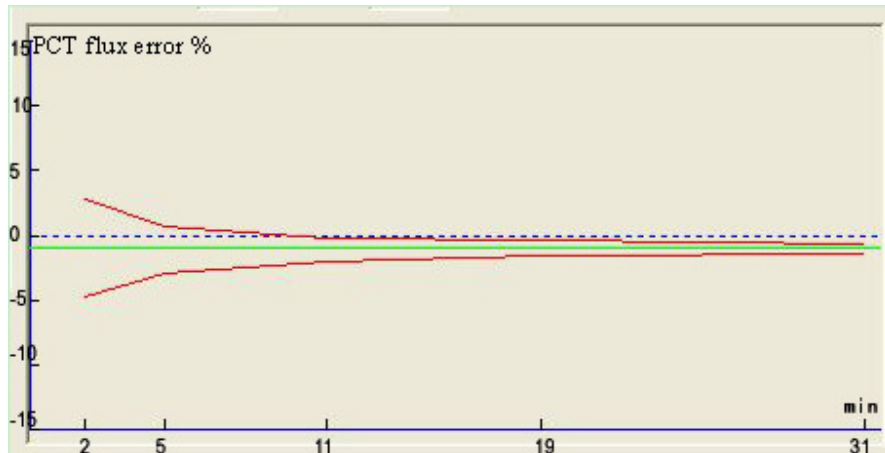



Fig. 5.2.4 Horn-shape curves when the rate is 5ml/h

	<p>Caution: Above test result is by using WEGO syringe recommended by the manufacturer. If other brand syringes are used, the result may deviate</p>
---	---

5.3 Occlusion Response Characteristics

- Occlusion alarm time is the most important index for the occlusion response characteristics. In this experiment, 50mL Shandong Weigao Jierui branded syringe is used. The following data are the result only by using this kind of syringe. Note: Occlusion alarm time is affected by the various factors including flow rate, syringe manufacturing techniques, syringe specification and solution quantity filled in, patient pipeline length and pressure, etc.

Items	Flow Rate (mL/h)	Occlusion Alarm Level	Occlusion Pressure (mmHg)	Occlusion Alarm Time
1	120	L	300	25 seconds
2	120	C	500	35 seconds
3	120	H	800	54 seconds
4	5	L	300	10 minutes and 1 seconds
5	5	C	500	15 minutes and 36 seconds
6	5	H	800	20 minutes and 43 seconds
7	1	L	300	50 minutes and 20 seconds

8	1	C	500	1 hour 15 minutes and 1 seconds
9	1	H	800	1 hour 29 minutes and 50 seconds

- Bolus dose caused by occlusion alarm: In this experiment, Shandong WEGO Jierui 50ml syringes are used, inject at the rate of 5ml/h, If the alarm pressure is set as low, the bolus dose is 0.06ml; If the alarm pressure is set as high, the bolus dose is 0.2ml/h.

6. Product Standard Configuration

- Syringe Pump: 1
- Power cord: 1
- Pump fastener: 1
- User manual: 1
- Certificate of conformity: 1
- Warranty card: 1

7. Related Information

Manufacturer: Sino Medical-Device Technology Co., Ltd.

Registration address: 6th Floor, No.15 Building, Majialong Industrial Zone,
Nanshan District, Shenzhen, P.R. China

Manufacturing address: 6th Floor, No.15 Building, Majialong Industrial Zone,
Nanshan District, Shenzhen, P.R. China

Tel: 0086 755 26755692

Fax: 0086 755 26755687

Zip code: 518052

Website: www.sinomdt.com

Email: info@sinomdt.com

After-service provider: Sino Medical-Device Technology Co., Ltd.

Hotline: 0086 400 886 0121

Fax: 0086 755 26755687

Zip code: 518052

Address: 6th Floor, No.15 Building, Majialong Industrial Zone, Nanshan
District, Shenzhen, P.R. China

Shanghai International Holding Corp. GmbH (Europe)

Add: Eiffestrasse 80, 20537 Hamburg, Germany

Tel: +49-40-2513175

Fax: +49-40-255726

E-mail: shholding@hotmail.com